

THIS UNIT IS ADJUSTABLE FROM 4" TO 6 1/4" BEAM FLANGE WIDTH

NO. REQ.

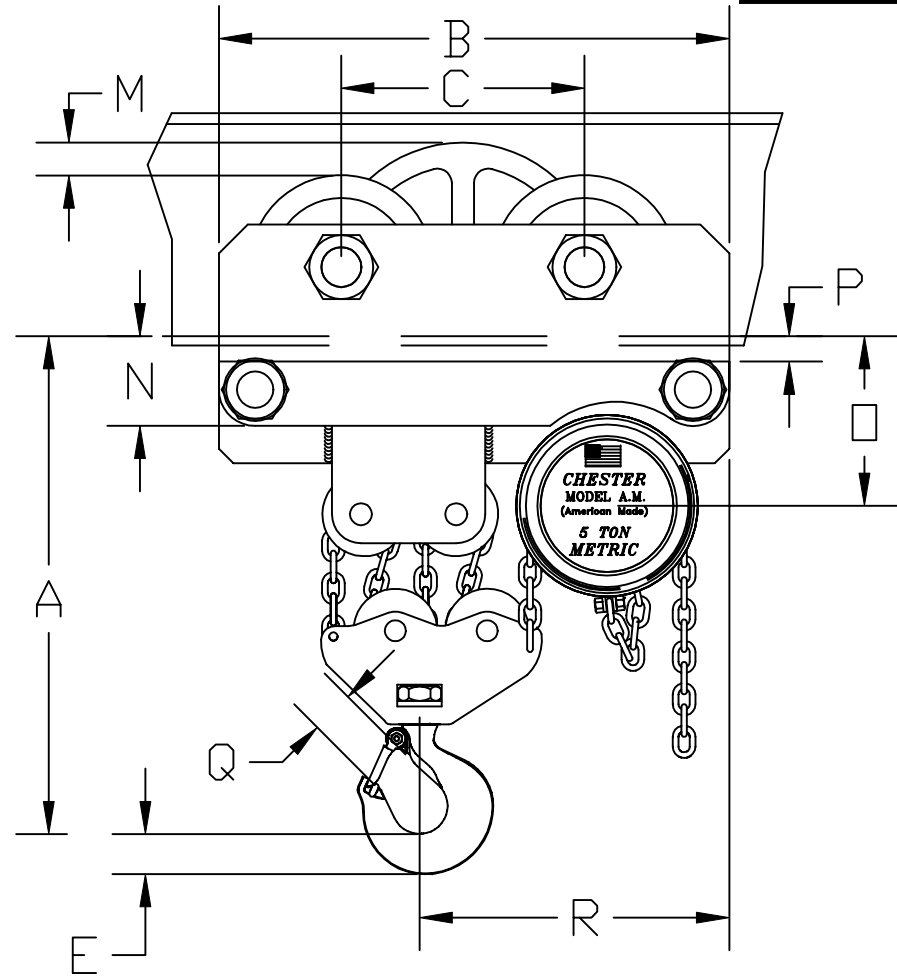
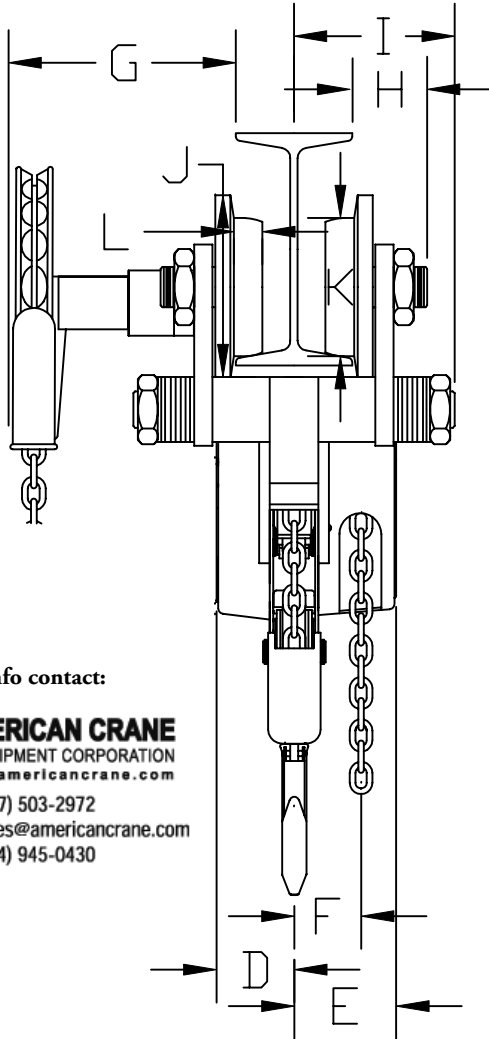

For more info contact:

ACECO
AMERICAN CRANE
 & EQUIPMENT CORPORATION
 www.americancrane.com

Phone (877) 503-2972
 E-mail sales@americancrane.com
 Fax (484) 945-0430

A	B	C	D	E	F	G	H	I	J	K	L	M	N	O	P	Q	R
18 5/16"	17 9/16"	8 3/16"	2 13/16"	1 7/16"	2 1/2"	6 13/16"	2 5/8"	5 7/16"	6 11/32"	4 3/4"	1"	1 1/4"	3 1/8"	5 7/8"	7/8"	1 3/8"	9 3/16"

* FOR PLAIN UNITS "I" IS THE SAME FOR BOTH SIDES OF UNIT
 MAX. LIFT FOR THIS UNIT IS 30'

5 METRIC TON CHESTER "AM"
 ARMY TYPE HOIST

CHESTER HOIST
 LISBON, OHIO

DR. RLB | TR. | CK. | AP.

SCALE NONE | DATE 11-21-00

REF. DWG. NO.

Dwg. No. CD074

MK. REVISIONS CK-DATE