

EC-1 (Hook Mount) EC-0516 to EC-1032 (1/4 to 1/2 Ton) Single Chain

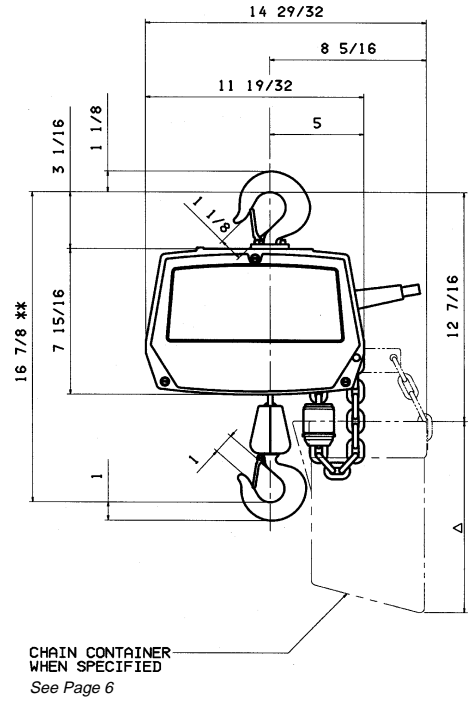

EC-1 (Hook Mount) EC-2012 and EC-2016 (1 Ton) Single Chain

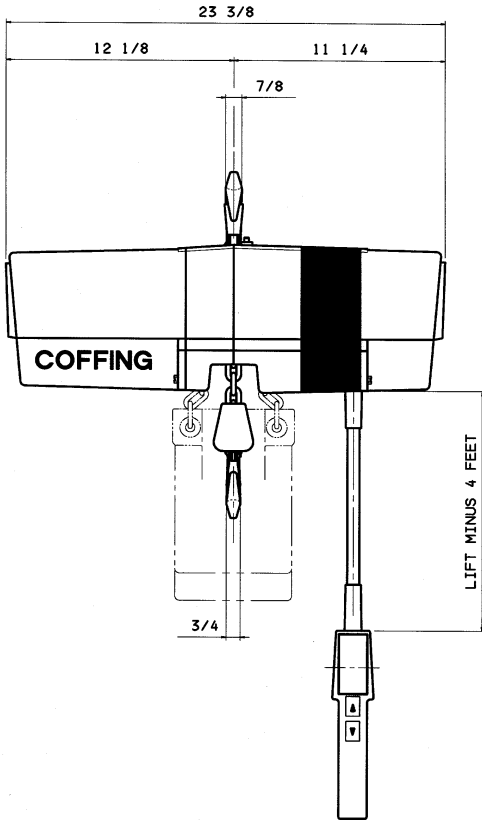
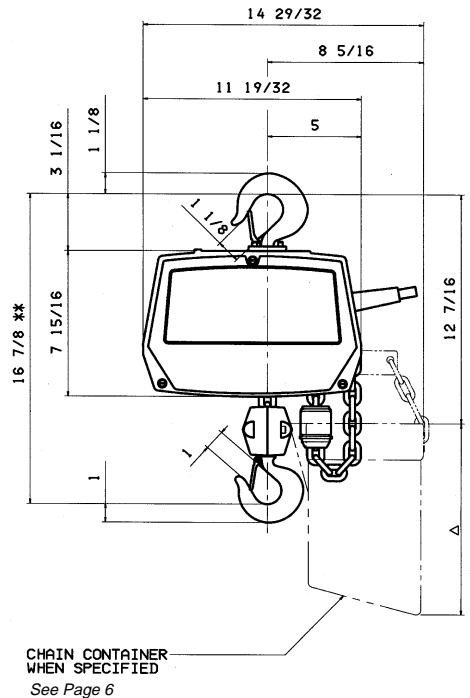
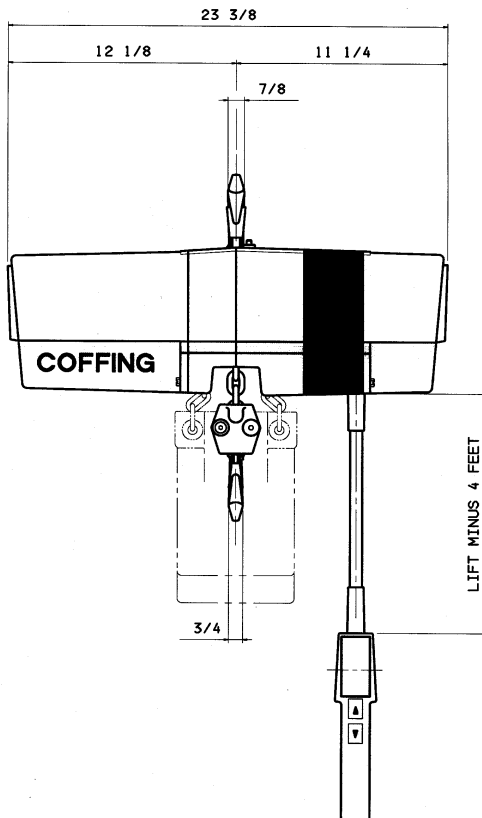

** This dimension allows for 2" clearance between load block and underside of hoist for single chain models.

EC-1 (Hook Mount) EC-2004 and EC-2008 (1 Ton) Double Chain

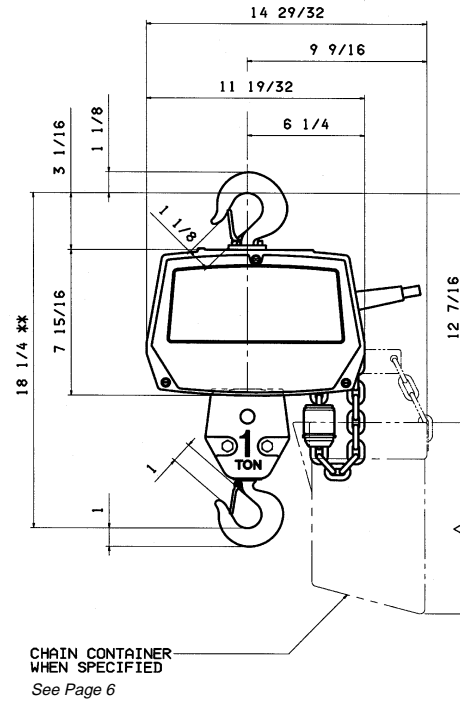
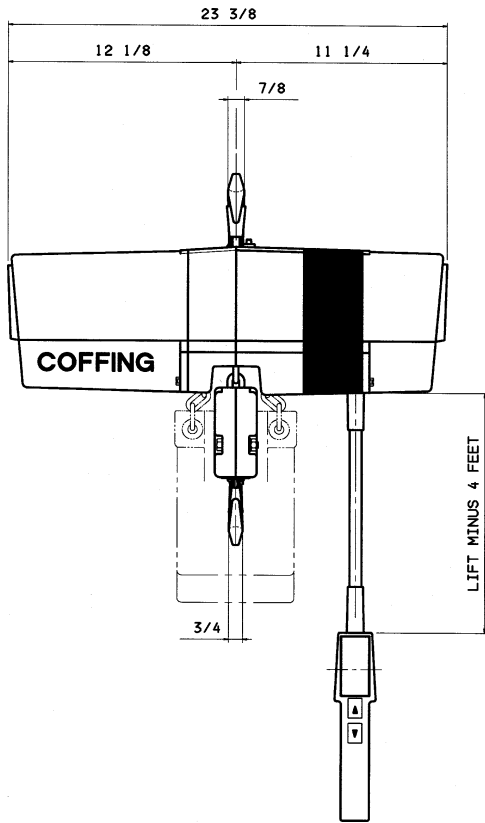

EC-1 (Hook Mount) EC-4006 and EC-4008 (2 Ton) Double Chain

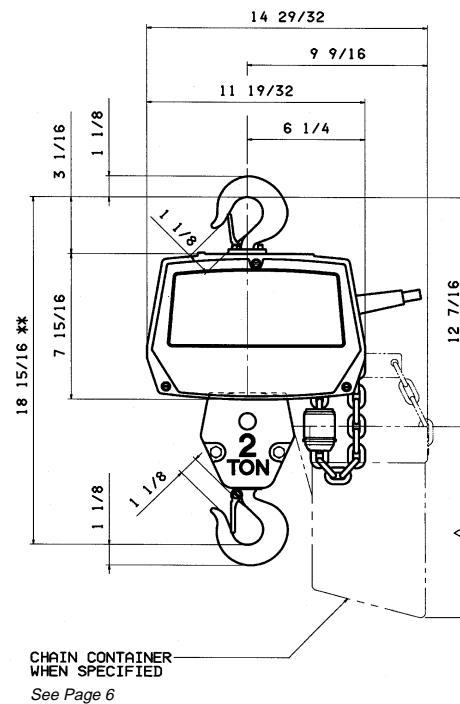
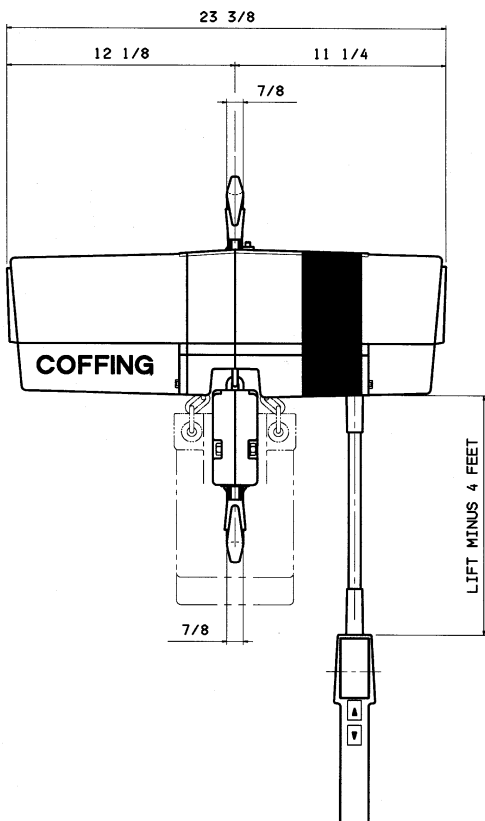

** This dimension allows for 1" clearance between load block and underside of hoist for multiple chain models.

EC-1 (Hook Mount) EC-6005 (3 Ton) Triple Chain

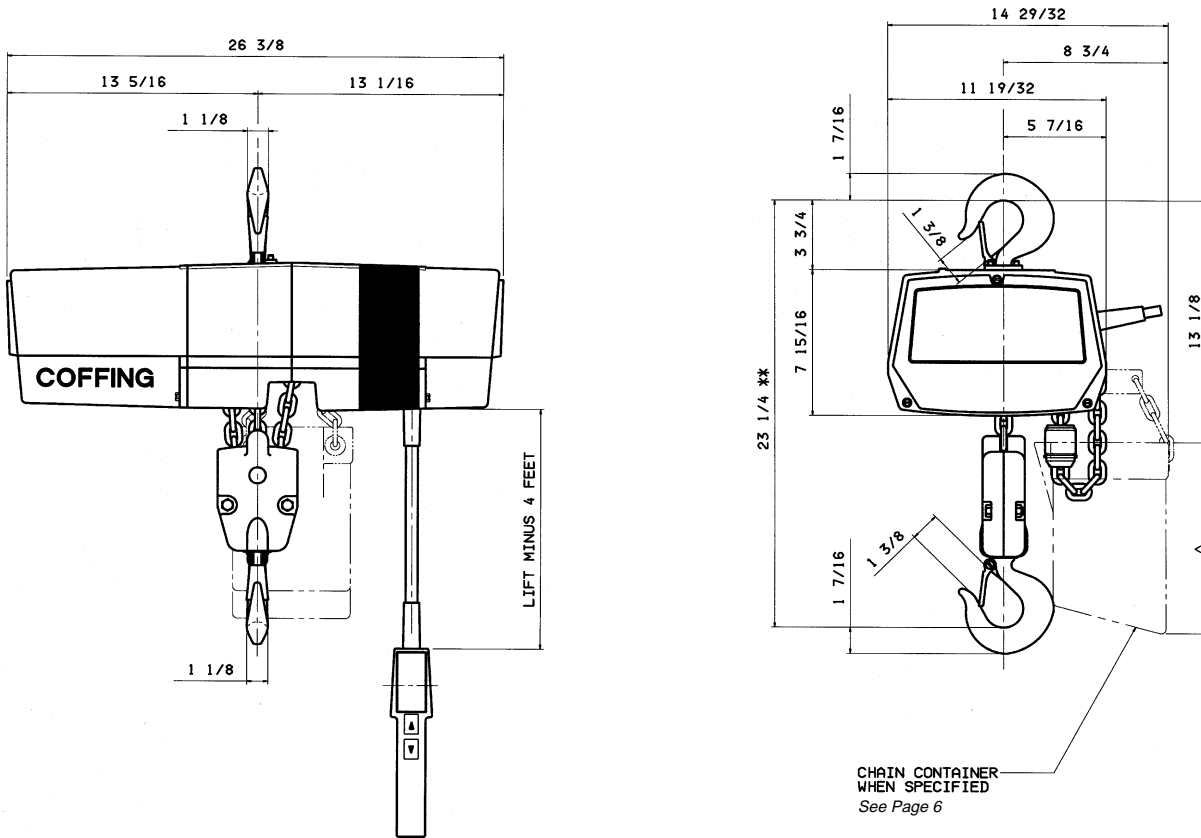

EC-3 (Hook Mount) EC-2032 (1 Ton), EC-4016, EC-4024 (2 Ton) Single Chain

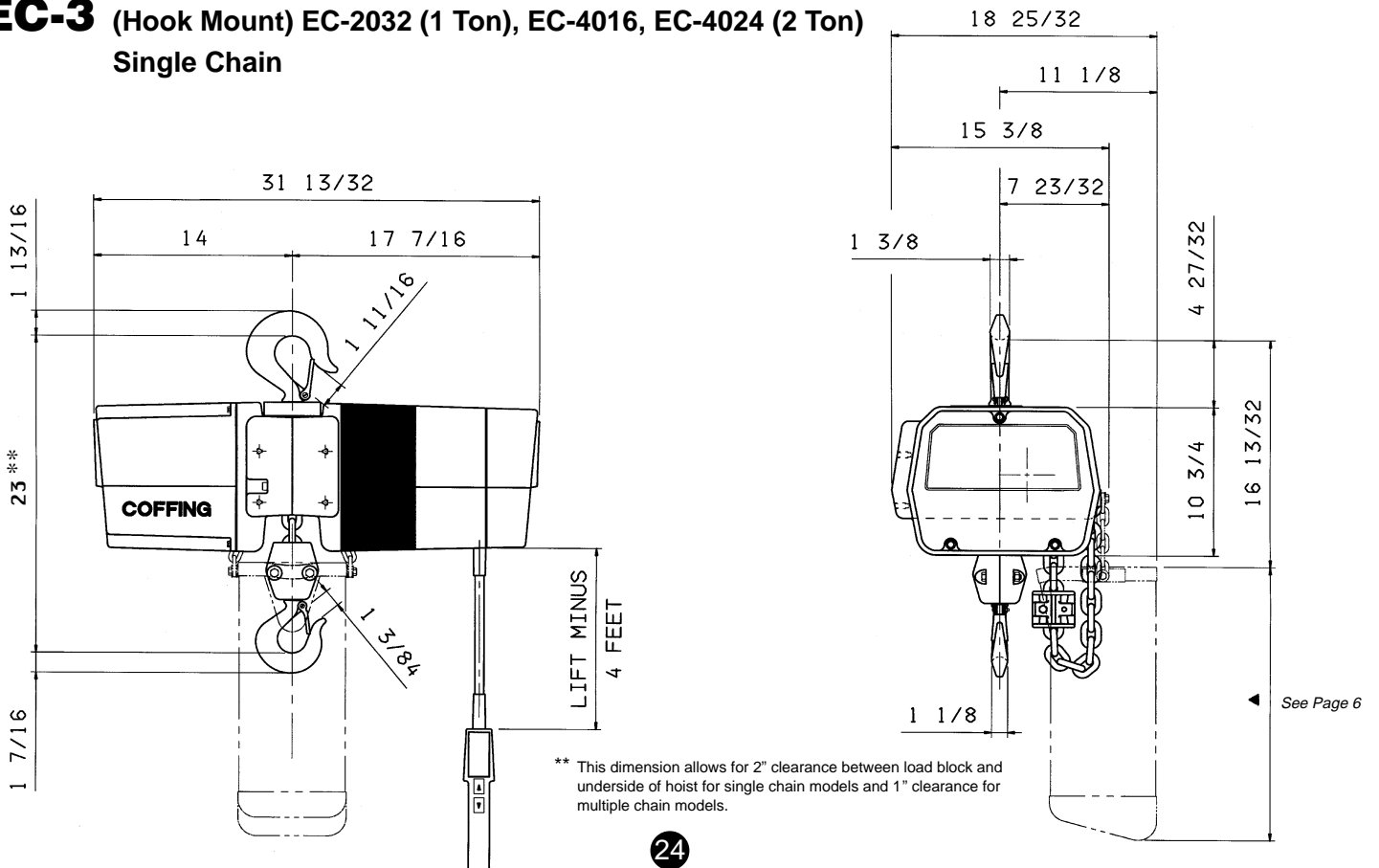

EC-3 (Hook Mount) EC-6010, EC-6016 (3 Ton)
EC-8008, EC-8012 (4 Ton) Double Chain

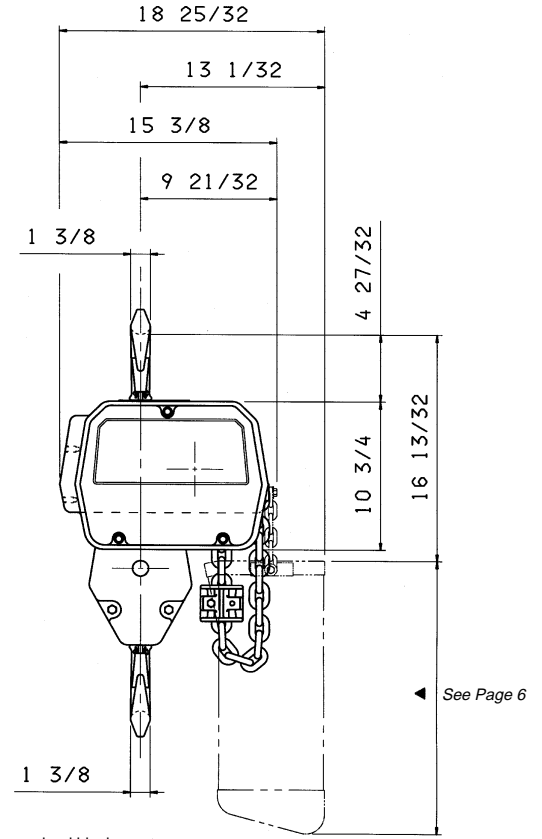
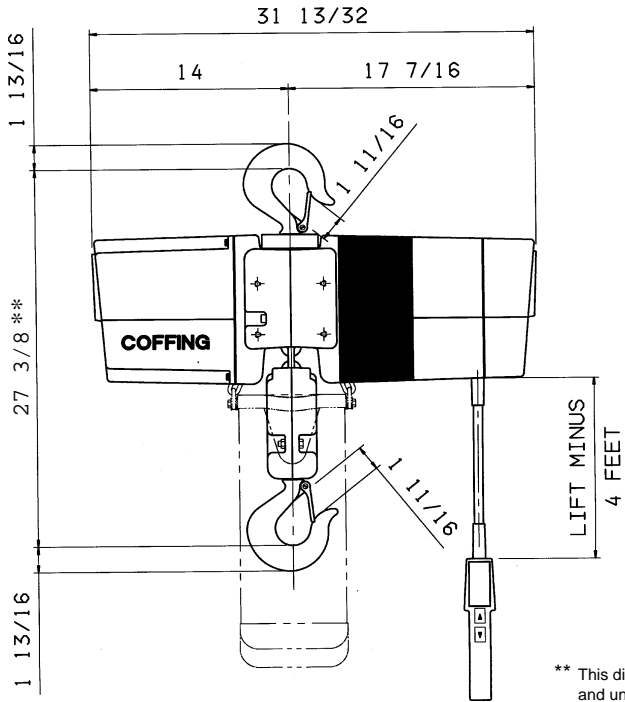

** This dimension allows for 1 1/2" clearance between load block and underside of hoist.

See Page 6

EC-1 (Lug Mount 50JG11) EC-0516 to EC-1032 (1/4 to 1/2 Ton) Single Chain

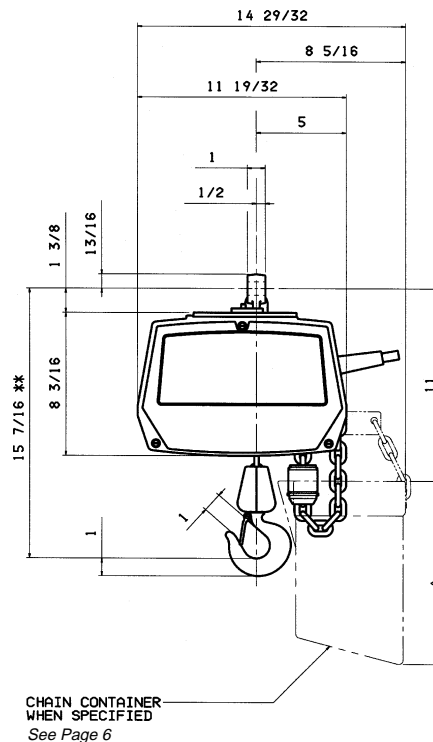
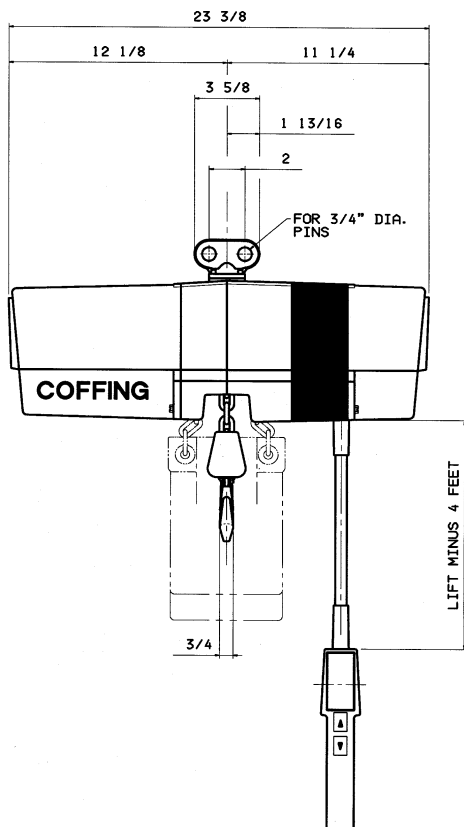

** This dimension allows for 2" clearance between load block and underside of hoist.