

## CAPACITIES UP TO 100 TON

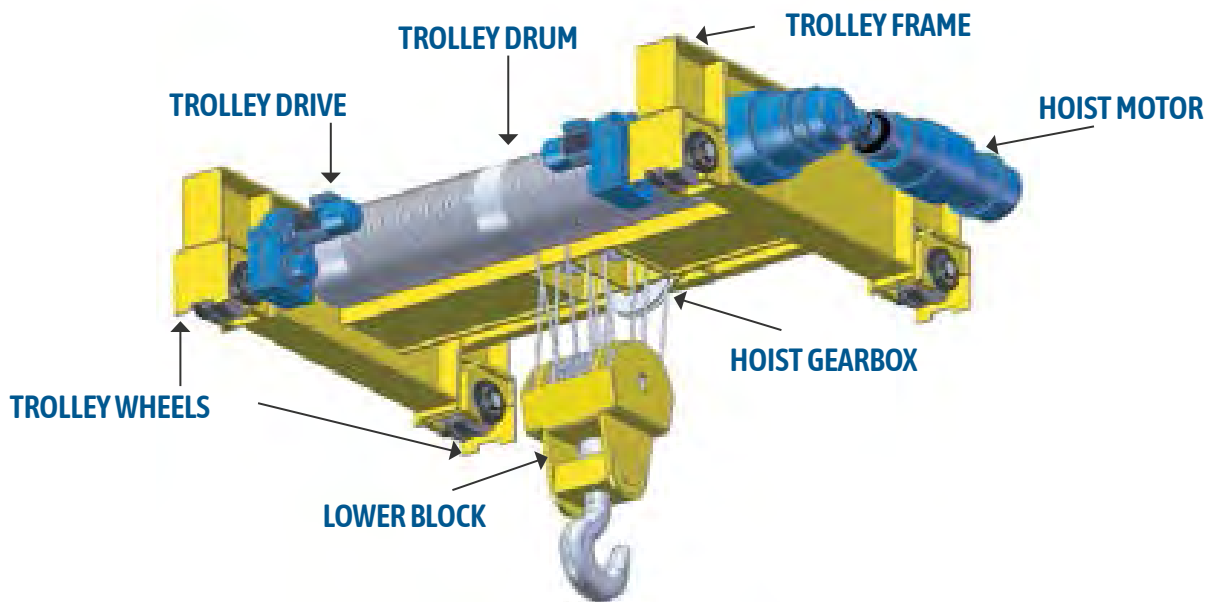

### HOIST BRAKE

Fail Safe, Spring Set, Electrically Released totally enclosed Disc Type Brake with self-adjusting mechanism to automatically compensate for lining wear. Unitized construction for easy disc replacement.

### TROLLEY WHEELS

Forged Steel, per AISI 1070, rim toughened to 320 Brinell minimum per ASTM A 504. Wheels are mounted on high strength alloy steel rotating axles, and supported by spherical roller bearings to provide a minimum L10 life of 10,000 hours.

### **LOWER BLOCK**

A fabricated steel housing supports ball bearing equipped steel sheaves. The forged steel hook features a minimum 5 to 1 design and is supported via a swiveling crosshead and roller type thrust bearing.

### **TROLLEY DRIVE**

Keyless Shaft Mounted, Parallel Helical Gearing with integral motor and brake. Gears manufactured from certified steel, heat treated to a case hardness of 58-62 Rockwell C, and finished ground or shaved to assure maximum mechanical efficiency.

### **LIMIT SWITCH**

Rotary Geared Type limit switch, directly driven by the hoist drum to accurately control upper and lower position of the block. The Switch features independently adjustable cams for precise control. A paddle type control circuit limit switch is also included.

### **TROLLEY FRAME**

Welded Steel construction from rolled shapes, and precision bored. The hoist frame is designed to rigidly support all machinery with minimal deflection for long service life. All welding is performed inhouse in accordance with AWS D1.1 by AWS Certified Welders.

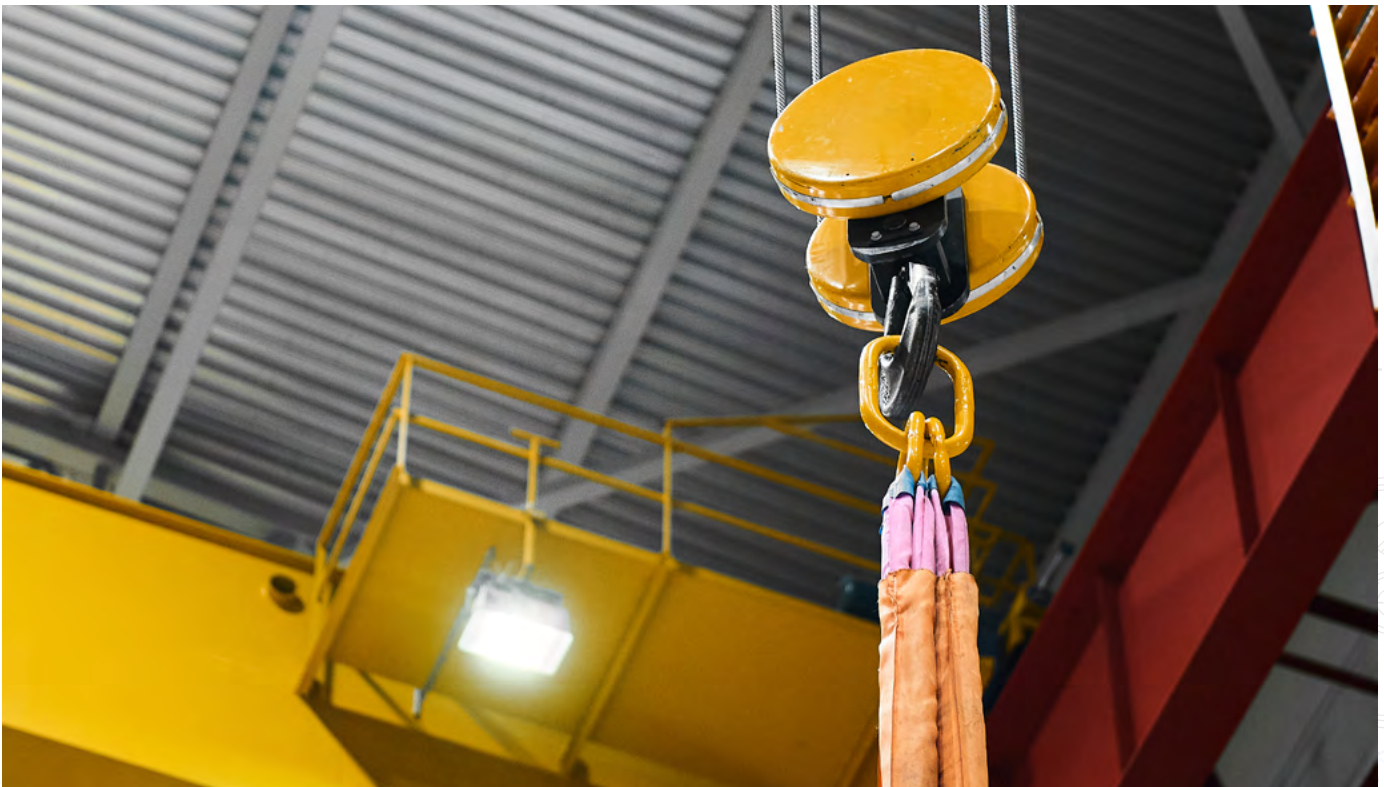



### **HOIST GEARBOX**

TDuctile Cast Iron fully enclosed gearbox with hardened alloy steel planetary gearing rigidly supported by heavy duty tapered roller bearings for high load capacity and long service life.

### **HOIST MOTOR**

Variable Speed Vector Motor with High Temperature Class Hinsulation to ensure reliability. Flange mounted ribbed frame construction with 100% copper conductors capable of 1000 to 1 speed range. The ACECO Vector motor is custom built, handcrafted and long lasting due to oversize frames. Motor Encoders are Mill Duty type with state of the art sensors that are unaffected by common contaminants. The encoder enclosure is of ductile cast iron construction for rugged reliability.

### **DRUM**

Seamless Tubing with machined left hand and right hand grooves, with groove depth and pitch per CMAA 70 Specifications. The drum is supported with a “barrel” type coupling at the connection to the hoist gearbox, there by avoiding a statically indeterminate loading condition. The opposite drum end is supported by a spherical roller bearing.

531 Old Swede Road · Douglassville, PA 19518 · 877.877.6778 · 610.385.6061  
info@AmericanCrane.com · www.AmericanCrane.com

