

Single Drive

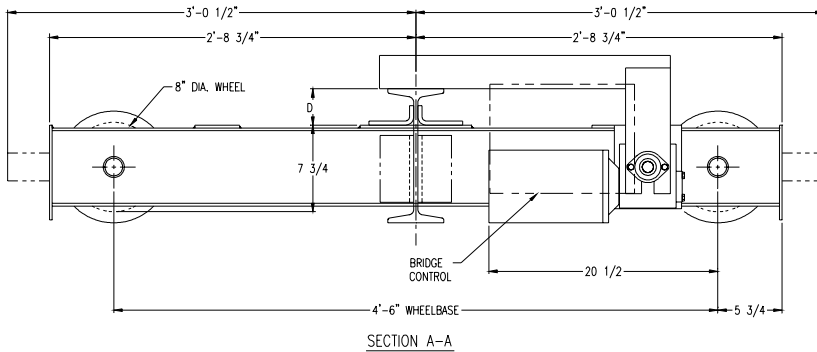

Beams (Depth)	D
6", 7", 8", 10" & 12"	3-1/4"
15", 18" & 20"	4-3/4"

$$J=7-3/4" + D + 3"$$

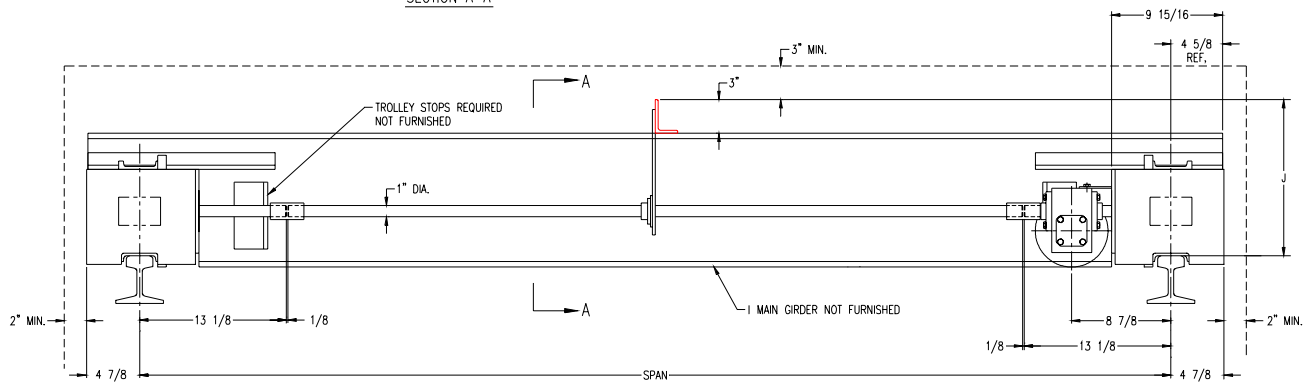

Dual Drive - 36' Spans*

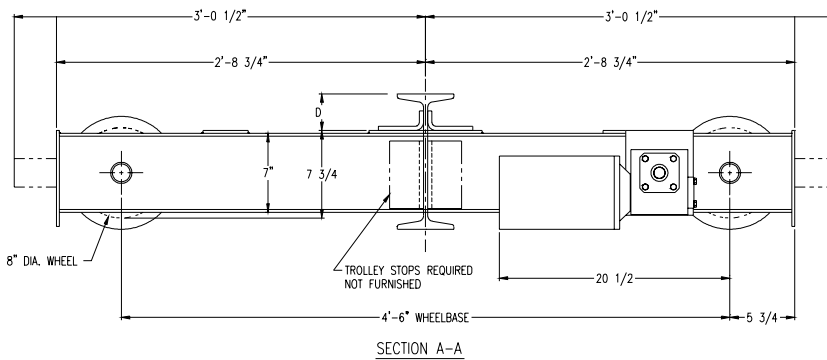

Beams (Depth)	D
6", 7", 8", 10" & 12"	3-1/4"
15", 18" & 20"	4-3/4"

$$J=7-3/4" + D + 3"$$

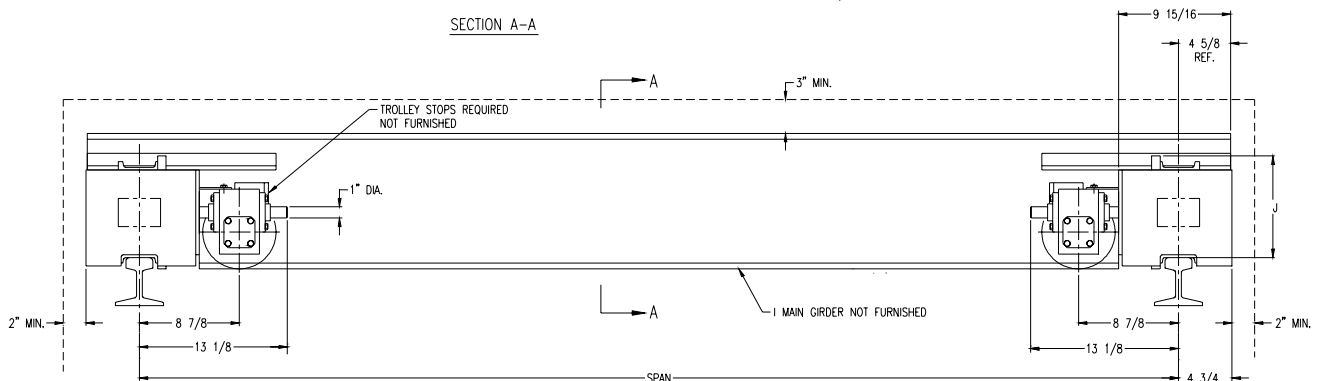

* For spans from 36' up to 48' consult factory.