

CHESTER HOIST

WORM DRIVE HOIST
DATA SHEET E-78AS

CAPACITY 2-3 TON

LOW HEADROOM
MOTORIZED TROLLEY - S

SINGLE HOOK MONORAIL
2-PART DOUBLE

FOR MORE INFO CONTACT: American Crane & Equipment Corp. - Authorized Distributor
Tel: 877-503-2972 Fax: 484-945-0430 Email: sales@americancrane.com Website: www.americancrane.com

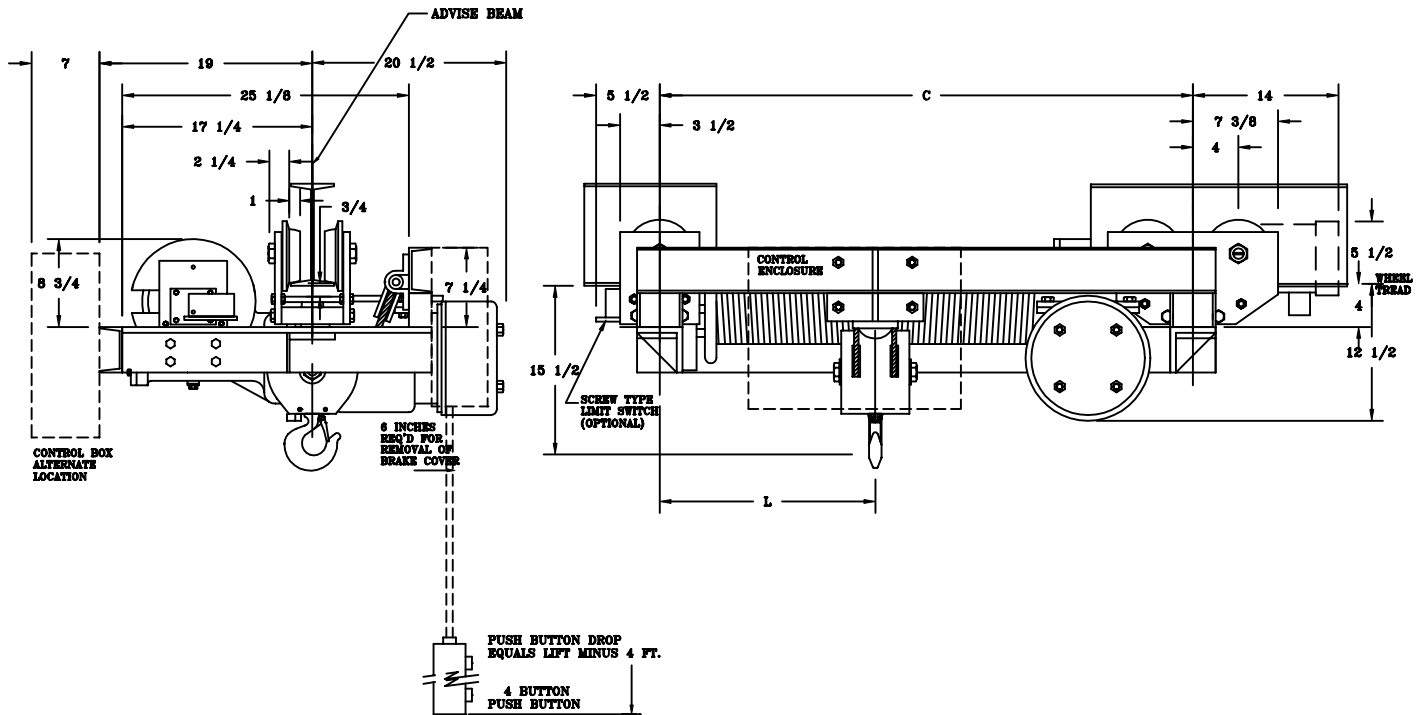

ALL DIMENSIONS IN INCHES

MODEL NUMBER	CAPACITY (lbs.)	SPEED (fpm)	LIFT (ft.)	REEVING	MOTOR (hp)	C	L	ST'D. I-BEAM		APPROX. WT. (lbs.)
								SIZE	CLEAR*	
WDMT-41S	4000	20	20	2PD-1/4	4 @ 1200	43 3/8	15	7-18	3/16	825
WDMT-42S	4000	20	30	2PD-1/4	4 @ 1200	52 1/8	19 1/4	7-18	3/16	875
WDMT-42AS	4000	20	55	2PD-1/4	4 @ 1200	62 1/8	24 1/4	7-18	3/16	925
WDMT-44S	4000	30	20	2PD-1/4	6 @ 1800	43 3/8	15	7-18	3/16	850
WDMT-45S	4000	30	30	2PD-1/4	6 @ 1800	52 1/8	19 1/4	7-18	3/16	900
WDMT-45AS	4000	30	55	2PD-1/4	6 @ 1800	62 1/8	24 1/4	7-18	3/16	950
WDMT-67S	6000	20	20	2PD-5/16	6 @ 1200	43 3/8	15	7-18	3/16	850
WDMT-68S	6000	20	30	2PD-5/16	6 @ 1200	52 1/8	19 1/4	7-18	3/16	900
WDMT-68AS	6000	20	55	2PD-5/16	6 @ 1200	62 1/8	24 1/4	7-18	3/16	950

* CLEARANCE BASED ON MAX. "S" BEAM SIZE 18" @ 70 LBS.
TROLLEYS FOR OTHER I-BEAMS AND PATENTED TRACKS ARE AVAILABLE.
MAXIMUM BEAM FLANGE WIDTH 6 1/4 INCHES.
NOTE: WHEN USING SCREW TYPE LIMIT SWITCH ADD 1 INCH TO HEADROOM.